

NOTES:

1. D1-5: 1N4007
2. PCB: JMP50B
3. Effects loop components shown on preamp cct. diag.
4. Output impedance select can be wired for either 8 & 16Ω (normal) or 4 & 8Ω.
5. V3: ECC83
V4-7: EL34
6. Undesignated components are off-PCB components.
7. All resistors are 1/4w unless stated otherwise.

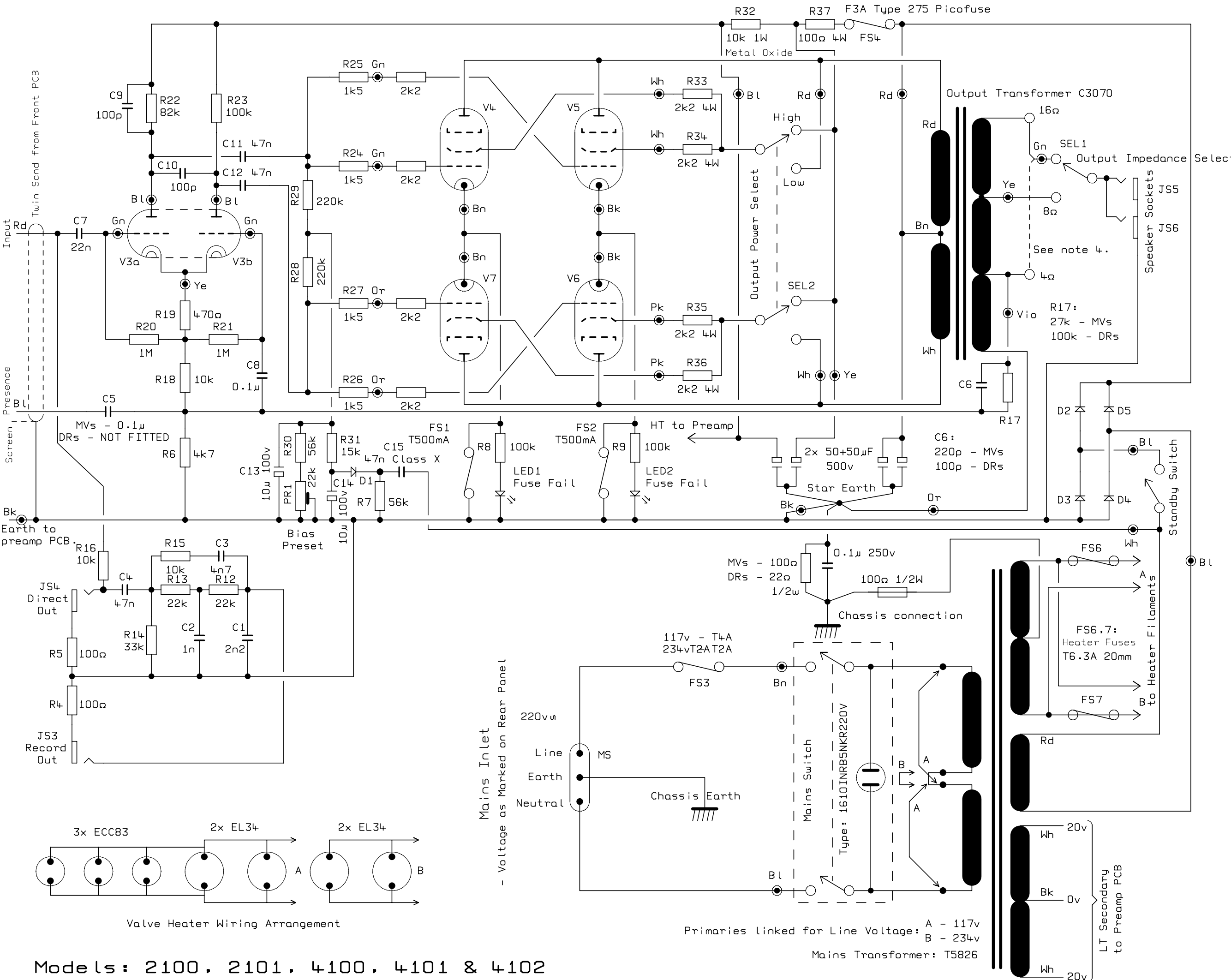

Mains Inlet
- Voltage as Marked on Rear Panel

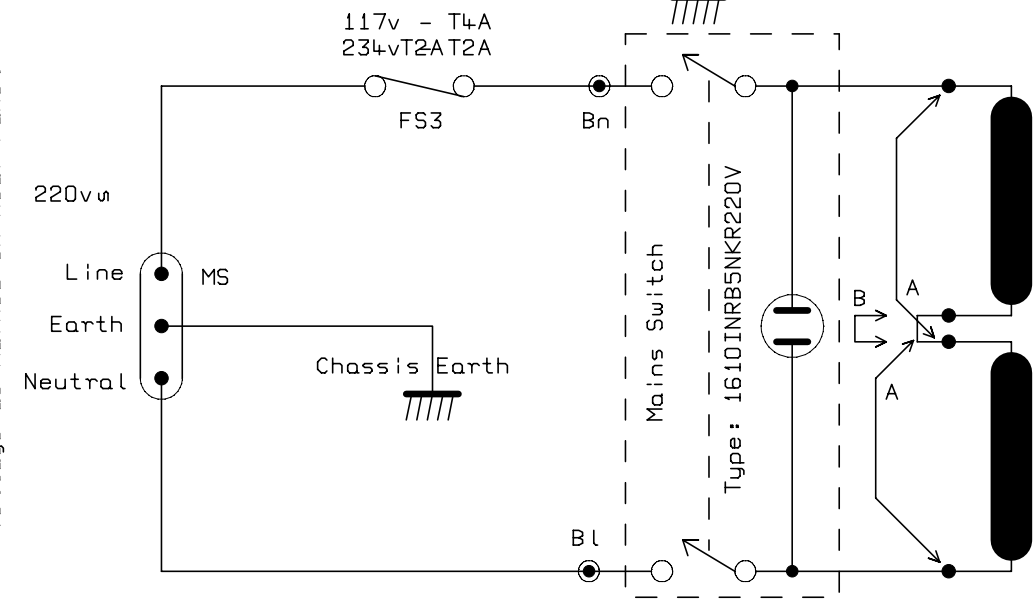

Primaries linked for Line Voltage: A - 117v
B - 234v
Mains Transformer: T5826

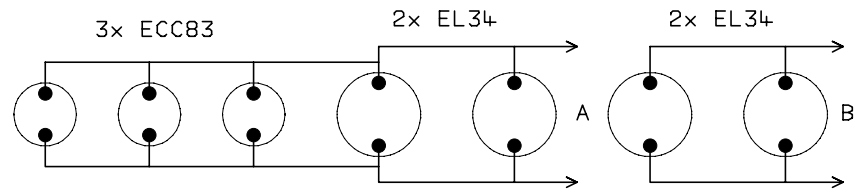

Valve Heater Wiring Arrangement

Models: 2100, 2101, 4100, 4101 & 4102

7	2-7-90	CPV
6	16-5-90	CPV
5	9-3-90	CPV
Iss.	Date	Drn.

Dwg. Number: CD0192
JCM900 Series
 100w Power Amp
 Circuit Diagram
NOTES
Marshall
 Jim Marshall
 (Products) Ltd.
 BLETCHLEY
 MILTON KEYNES
 ENGLAND
 File: CD0192.DGM

